

Reducing Coupling Style 020

VISION



Style 020 Reducing Coupling is designed with flat-pad, to create flexibility of the pipeline in both axial and angular direction, by keeping a certain gap between the housing key and pipe groove. Style 020 Reducing Coupling is an alternative and economic option to replace a combination of two couplings and a concentric reducer. The unique G02 "C" shape gasket performs triple sealing functions with tested and proven compression set and pocket volumetric, which maintains enough seal function when the coupling is deflected.

Size:

- DN40*32-DN200*150 | 1-1/2*1-1/4-8*6"

Maximum Working Pressure:

- 3.5MPa(500psi)
- Working pressure depend on material, wall thickness and pipe size

Material Specifications

Housing:

Ductile iron confirming to ASTM A536, Grade 65-45-12, other material also available, please consult VISION.

Coating:

Orange-Standard

Red- Optional

Hot-Dipped, Zinc Galvanized-Optional

Bolts/Nuts:

Heat-treated plated carbon steel, trackhead meeting the physical and chemical requirements of ASTM A-449 and physical requirements of ASTM A-183.

Gasket:

Grade "E" EPDM gaskets have a green striped color code identification and conform to ASTM D2000 for service temperatures from -34°C to 110°C(-30°F to 230°F). They are recommended for hot water not to exceed 110°C(230°F), plus a variety of dilute acids, oil free air, and many chemical service.

Grade "T" Nitrile gaskets have an orange striped color code identification and conform to ASTM D2000 for service temperatures from -29°C to 82°C(-20°F to 180°F). They are recommended for petroleum products, vegetable oils, mineral oils, and air with oil vapors. For more material of the gaskets, please refer to VISION publication 09.05.



NingBo VISION Pipe Fittings Ltd.,Co.

Tel: 0086-21-5954-6863, Fax: 0086-21-5954-3888

Email: samwu@visioninc.cn, web: www.visionmfr.com

DS-1006E.B

Reducing Coupling Style 020

VISION

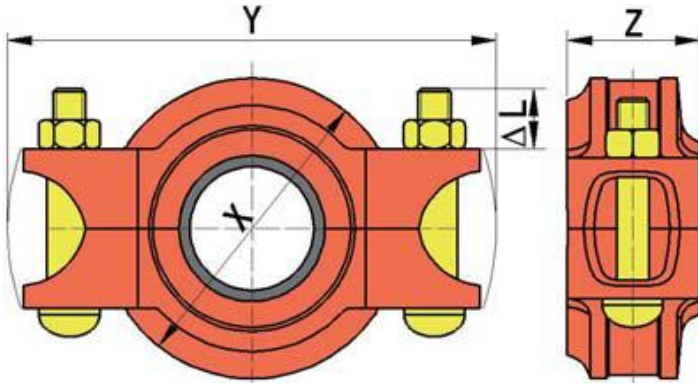

Size			Max.	Max.	Allowable	Deflection from Centerline		Dimensions				Bolt/Nut		Approximate
Main	×	Branch	Working Pressure	End Load	Pipe End Separation	per Cplg.	Pipe	X	Y	Z	ΔL	Size	Torque	Weight
mm		mm	Mpa	N	mm		mm/m	mm	mm	mm	mm	mm	N.m	kg
Inches		Inches	Psi	Lbs.	Inches	Degree	inches/ft	Inches	Inches	Inches	Inches	Inches	Lbs.ft	Lbs.
48.3	×	42.4	3.5	4869	0-2.44	—	—	70	107	45	15	M10×50	40-60	0.7
1½		1¼	500	1082	0-0.10	—	—	2.76	4.21	1.77	0.59	¾×2	30-44	1.5
60.3	×	42.4	3.5	4869	0-2.64	—	—	85	123	47	15	M10×50	40-60	0.9
2		1¼	500	1082	0-0.10	—	—	3.35	4.84	1.85	0.59	¾×2	30-44	2.0
		48.3	3.5	6318	0-2.64	—	—	85	123	47	15	M10×50	40-60	0.9
		1½	500	1417	0-0.10	—	—	3.35	4.84	1.85	0.59	¾×2	30-44	2.0
73.0	×	60.3	3.5	9847	0-2.94	—	—	97	146	49	23	M12×75	80-120	1.3
2½		2	500	2214	0-0.12	—	—	3.82	5.75	1.93	0.91	¾×3	59-89	2.9
88.9	×	60.3	3.5	9847	0-3.14	—	—	113	162	49	23	M12×75	80-120	1.6
3		2	500	2214	0-0.12	—	—	4.45	6.38	1.93	0.91	¾×3	59-89	3.5
		73.0	3.5	14432	0-3.14	—	—	113	162	49	23	M12×75	80-120	1.5
		2½	500	3244	0-0.12	—	—	4.45	6.38	1.93	0.91	¾×3	59-89	3.3
114.3	×	60.3	3.5	9847	0-4.04	—	—	143	202	51	32	M16×90	180-240	2.8
4		2	500	2214	0-0.16	—	—	5.63	7.95	2.01	1.26	¾×3½	133-177	6.2
		73.0	3.5	14432	0-4.04	—	—	143	202	51	32	M16×90	180-240	2.5
		2½	500	3244	0-0.16	—	—	5.63	7.95	2.01	1.26	¾×3½	133-177	5.5
		88.9	3.5	21404	0-4.04	—	—	143	202	51	32	M16×90	180-240	2.4
		3	500	4808	0-0.16	—	—	5.63	7.95	2.01	1.26	¾×3½	133-177	5.3
139.7	×	88.9	2.8	17061	0-4.04	—	—	170	238	51	36	M20×100	280-360	3.6
5½OD		3	400	3847	0-0.16	—	—	6.69	9.37	2.01	1.42	¾×4	207-267	7.9
		114.3	2.8	28203	0-4.04	—	—	170	238	51	36	M20×100	280-360	3.2
		4	400	6359	0-0.16	—	—	6.69	9.37	2.01	1.42	¾×4	207-267	7.1
141.3	×	88.9	2.8	17061	0-4.04	—	—	171	240	51	36	M20×100	280-360	3.6
5		3	400	3847	0-0.16	—	—	6.73	9.45	2.01	1.42	¾×4	207-267	7.9
		114.3	2.8	28203	0-4.04	—	—	171	240	51	36	M20×100	280-360	3.2
		4	400	6359	0-0.16	—	—	6.73	9.45	2.01	1.42	¾×4	207-267	7.1
165.1	×	114.3	2.8	28203	0-4.04	—	—	196	267	51	36	M20×100	280-360	4.1
6½OD		4	400	6359	0-0.16	—	—	7.72	10.51	2.01	1.42	¾×4	207-267	9.0
		139.7	2.8	42130	0-4.04	—	—	196	267	51	36	M20×100	280-360	3.7
		5½OD	400	9499	0-0.16	—	—	7.72	10.51	2.01	1.42	¾×4	207-267	8.2
168.3	×	114.3	2.8	28203	0-4.04	—	—	200	269	51	36	M20×100	280-360	4.2
6		4	400	6359	0-0.16	—	—	7.87	10.59	2.01	1.42	¾×4	207-267	9.3
		141.3	2.8	43101	0-4.04	—	—	200	269	51	36	M20×100	280-360	3.8
		5	400	9717	0-0.16	—	—	7.87	10.59	2.01	1.42	¾×4	207-267	8.4
219.1	×	165.1	2.8	58843	0-6.3	—	—	259	345	61	40	M22×130	400-480	6.9
8		6½OD	400	13267	0-0.25	—	—	10.20	13.58	2.40	1.57	¾×5¼	296-356	15.2
		168.3	2.8	61146	0-6.3	—	—	259	345	61	40	M22×130	400-480	6.8
		6	400	13782	0-0.25	—	—	10.20	13.58	2.40	1.57	¾×5¼	296-356	15.0

- The max. pipe end separation and deflection is for cut grooved standard weight pipe. Values for roll grooved pipe will be half of the cut grooved.
- Working Pressure and end load are total, from internal and external loads based on standard weight steel pipe.



NingBo VISION Pipe Fittings Ltd.,Co.

Tel: 0086-21-5954-6863, Fax: 0086-21-5954-3888

Email: samwu@visioninc.cn, web: www.visionmfr.com

DS-1006E.B