

# Flexible Coupling Style 101

# VISION



Style 101 Standard Flexible Coupling is designed with flat-pad housings, to create flexibility of the pipeline in both axial and angular direction, by keeping a certain gap between the housing key and pipe groove. Lateral movement is achieved by connection with two 101 Std. flexible couplings. The unique “C” shape gasket performs triple sealing functions. With tested and proven compression set and pocket volumetric, the gasket retains sealing capacity even if the pipe deflects or rotates.

#### Size:

- DN25-DN300 | 1-12”
- For Sizes 14” and up, please refer to UG28.

#### Maximum Working Pressure:

- 5.2MPa(750psi)
- Working pressure depend on material, wall thickness and pipe size

#### Material Specifications

##### Housing:

Ductile iron confirming to ASTM A536, Grade 65-45-12, other material also available, please consult VISION.

##### Coating:

Orange-Standard

Red- Optional

Hot-Dipped, Zinc Galvanized-Optional

##### Bolts/Nuts:

Heat-treated plated carbon steel, trackhead meeting the physical and chemical requirements of ASTM A-449 and physical requirements of ASTM A-183.

##### Gasket:

Grade “E” EPDM gaskets have a green striped color code identification and conform to ASTM D2000 for service temperatures from -34°C to 110°C(-30°F to 230°F). They are recommended for hot water not to exceed 110°C(230°F), plus a variety of dilute acids, oil free air, and many chemical service.

Grade “T” Nitrile gaskets have an orange striped color code identification and conform to ASTM D2000 for service temperatures from -29°C to 82°C(-20°F to 180°F). They are recommended for petroleum products, vegetable oils, mineral oils, and air with oil vapors. For more material of the gaskets, please refer to VISION publication 09.05.



NingBo VISION Pipe Fittings Ltd.,Co.

Tel: 0086-21-5954-6863, Fax: 0086-21-5954-3888

Email: samwu@visioninc.cn, web: www.visionmfr.com

DS-1003E.B

# Flexible Coupling Style 101

# VISION

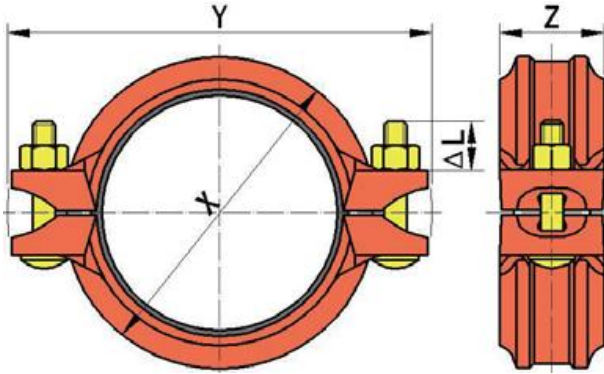

Size		Working Pressure	End Load	Pipe End Separation	Deflection from Centerline	Dimensions					Bolt/Nut		Weight
Nominal	Actual O.D.	Max.	Max.	Max.	per Cplg.	Pipe	X	Y	Z	ΔL	Size	Torque	Approximate
mm	mm	Mpa	N	mm	Degree	mm/m	mm	mm	mm	mm	mm	N.m	kg
Inches	Inches	Psi	Lbs.	Inches		inches/ft	Inches	Inches	Inches	Inches	Inches	Lbs.ft	Lbs.
25	33.4	3.45	3023	0-2.24	2°-43'	0.57	55	101	45	15	M10×50	40-60	0.5
1	1.315	500	679	0-0.09		48	2.17	3.98	1.77	0.59	3/8×2	30-44	1.1
32	42.4	3.45	4871	0-2.24	2°-10'	0.45	64	111	45	15	M10×50	40-60	0.6
1 1/4	1.660	500	1082	0-0.09		38	2.52	4.37	1.77	0.59	3/8×2	30-44	1.3
40	48.3	3.45	6321	0-2.24	1°-56'	0.40	70	117	45	15	M10×50	40-60	0.7
1 1/2	1.900	500	1418	0-0.09		33	2.76	4.61	1.77	0.59	3/8×2	30-44	1.4
50	60.3	3.45	9852	0-2.64	1°-31'	0.32	87	131	47	15	M10×50	40-60	0.8
2	2.375	500	2215	0-0.10		26	3.43	5.16	1.85	0.59	3/8×2	30-44	1.8
65	73.0	3.45	14440	0-2.94	1°-15'	0.26	101	150	49	15	M10×55	40-60	1.0
2 1/2	2.875	500	3246	0-0.12		22	3.98	5.91	1.93	0.59	3/8×2 1/4	30-44	2.4
80	88.9	3.45	21415	0-3.14	1°-2'	0.22	118	165	49	15	M10×55	40-60	1.2
3	3.500	500	4811	0-0.12		18	4.65	6.50	1.93	0.59	3/8×2 1/4	30-44	2.6
90	101.6	3.45	27970	0-3.54	0°-54'	0.19	133	181	51	23	M12×75	80-120	1.7
3 1/2	4.000	500	6283	0-0.14		16	5.24	7.13	2.01	0.91	1/2×3	59-89	4.0
100	114.3	3.45	35400	0-3.74	1°-36'	0.34	147	201	53	23	M12×75	80-120	1.9
4	4.500	500	7950	0-0.15		28	5.79	7.91	2.09	0.91	1/2×3	59-89	4.2
125	139.7	3.1	47516	0-4.04	1°-18'	0.28	174	241	53	32	M16×90	180-240	2.5
5 1/2 OD	5.500	450	10691	0-0.16		24	6.85	9.49	2.09	1.26	3/4×3 1/2	133-178	5.5
125	141.3	3.1	48611	0-4.04	1°-18'	0.27	176	243	53	32	M16×90	180-240	2.5
5	5.563	450	10938	0-0.16		23	6.93	9.57	2.09	1.26	3/4×3 1/2	133-178	5.5
150	165.1	3.1	66366	0-4.74	1°-7'	0.23	205	271	53	32	M16×90	180-240	2.9
6 1/2 OD	6.500	450	14932	0-0.19		58	8.07	10.67	2.09	1.26	3/4×3 1/2	133-178	6.4
150	168.3	3.1	68964	0-4.74	1°-5'	0.23	205	286	53	32	M16×90	180-240	3.1
6	6.625	450	15512	0-0.19		58	8.07	11.26	2.09	1.26	3/4×3 1/2	133-178	6.8
175	193.7	3.1	91350	0-4.90	-	-	233	316	61	36	M20×100	280-360	4.8
7	7.626	450	20554	0-0.19	-	-	9.17	12.44	2.40	1.42	3/4×4	207-267	10.6
200A	216.3	3.1	113911	0-4.90	0°-51'	0.18	258	330	63	36	M20×100	280-360	5.4
8	8.500	450	25535	0-0.19		46	10.16	12.99	2.48	1.42	3/4×4	207-267	11.7
200	219.1	3.1	116879	0-4.90	0°-50'	0.18	263	341	63	36	M20×100	280-360	5.4
8	8.625	450	26292	0-0.19		14	10.35	13.43	2.48	1.42	3/4×4	207-267	11.7
250A	267.4	2.76	154996	0-4.90	-	-	312	391	63	36	M20×120	280-360	7.5
10	10.525	400	34801	0-0.19	-	-	12.28	15.39	2.48	1.42	3/4×4 3/4	207-267	16.5
250	273.0	2.76	161556	0-4.90	-	-	319	402	63	36	M20×120	280-360	7.5
10	10.750	400	36305	0-0.19	-	-	12.56	15.83	2.48	1.42	3/4×4 3/4	207-267	16.5
300A	318.5	2.76	219896	0-4.90	-	-	362	449	64	36	M20×120	280-360	11.5
12	12.525	400	49284	0-0.19	-	-	14.25	17.68	2.52	1.42	3/4×4 3/4	207-267	26.2
300	323.9	2.76	227416	0-4.90	-	-	370	455	64	36	M20×120	280-360	11.9
12	12.750	400	51070	0-0.19	-	-	14.57	17.91	2.52	1.42	3/4×4 3/4	207-267	26.2

- The max. pipe end separation and deflection is for cut grooved standard weight pipe. Values for roll grooved pipe will be half of the cut grooved.
- Working Pressure and end load are total, from internal and external loads based on standard weight steel pipe.



NingBo VISION Pipe Fittings Ltd., Co.

Tel: 0086-21-5954-6863, Fax: 0086-21-5954-3888

Email: samwu@visioninc.cn, web: www.visionmfr.com

DS-1003E.B