

# Flange Adapter Style 007D2

# VISION



Style 007D2 provides a rigid connection with a spigot and socket design. Diameter between key sections is adjusted by tightening nuts until key section grips groove bottom around the full circumference rigidity. Style 007D2 Flange Adapter is Not allowed linear movement and rotating due to a inner tooth design. Style 007D2 Flange Adapter is a rigid coupling, it is applied to connect grooved Valves tightly prevent rotating.

#### Size:

- DN50-DN300 | 2-12"
- For Sizes 14" and up, please refer to 015.

#### Maximum Working Pressure:

- 3.5MPa(500psi)
- Working pressure depend on material, wall thickness and pipe size

#### Material Specifications

##### Housing:

Ductile iron confirming to ASTM A536, Grade 65-45-12, other material also available, please consult VISION.

##### Coating:

Orange-Standard

Red- Optional

Hot-Dipped, Zinc Galvanized-Optional

##### Bolts/Nuts:

Heat-treated plated carbon steel, trackhead meeting the physical and chemical requirements of ASTM A-449 and physical requirements of ASTM A-183.

##### Gasket:

Grade "E" EPDM gaskets have a green striped color code identification and conform to ASTM D2000 for service temperatures from -34°C to 110°C(-30°F to 230°F). They are recommended for hot water not to exceed 110°C(230°F), plus a variety of dilute acids, oil free air, and many chemical service.

Grade "T" Nitrile gaskets have an orange striped color code identification and conform to ASTM D2000 for service temperatures from -29°C to 82°C(-20°F to 180°F). They are recommended for petroleum products, vegetable oils, mineral oils, and air with oil vapors. For more material of the gaskets, please refer to VISION publication 09.05.



# Flange Adapter Style 007D2

# VISION

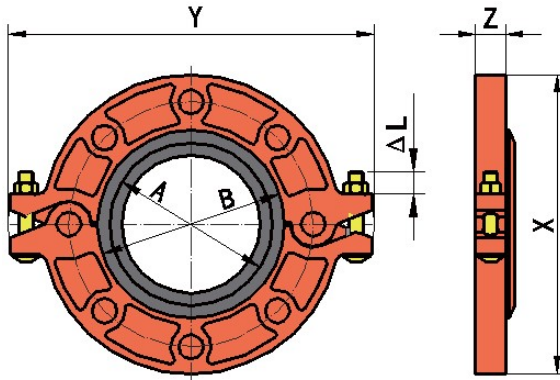

SIZE		Max.	Max.	Sealing Surface		Pipe End Separation	Dimensions					Bolt/Nut		Approximate
Nominal	Actual O.D.	Working Pressure	End Load	A	B	Max.	X	Y	Z	ΔL	Size	Torque	Weight	
mm	mm	Mpa	N	mm	mm	mm	mm	mm	mm	mm	mm	N.m	kg	
Inches	Inches	Psi	Lbs.	Inches	Inches	Inches	Inches	Inches	Inches	Inches	Inches	Lbs.ft	Lbs	
50	60.3	3.5	10	61	78		162	214	22	15	M10×60	40-60	1.8	
2	2.375	500	2214	2.40	3.07		6.38	8.43	0.87	0.59	¾×2½	30-44	4.0	
65	76.1	3.5	16	77	94		182	234	22	15	M10×60	40-60	2.1	
3OD	3.000	500	3533	3.03	3.70		7.17	9.21	0.87	0.59	¾×2½	30-44	4.6	
80	88.9	3.5	22	90	107		197	249	22	15	M10×60	40-60	2.3	
3	3.500	500	4808	3.54	4.21		7.76	9.80	0.87	0.59	¾×2½	30-44	5.1	
100	108.0*	3.5	31589	109	127		217	269	22	15	M10×60	40-60	2.4	
4¼OD	4.250	500	7090	4.29	5.00		8.54	10.59	0.87	0.59	¾×2½	30-44	5.3	
100	114.3	3.5	36	116	133		217	269	22	15	M10×60	40-60	2.5	
4	4.500	500	7948	4.57	5.24		8.54	10.59	0.87	0.59	¾×2½	30-44	5.5	
125	133.0*	3.5	47906	135	153		247	309	22	23	M12×75	80-120	3.1	
5¼OD	5.250	500	10818	5.31	6.02		9.72	12.17	0.87	0.91	¾×3	59-89	6.8	
125	139.7	3.5	54	141	159		247	309	22	23	M12×75	80-120	3.2	
5½OD	5.500	500	11873	5.55	6.26		9.72	12.17	0.87	0.91	¾×3	59-89	7.1	
150	159.0*	3.5	68467	161	180		282	344	24	23	M12×75	80-120	4.1	
6¼OD	6.250	500	15332	6.34	7.09		11.10	13.54	0.94	0.91	¾×3	59-89	9.0	
150	165.1	3.5	75	167	186		282	344	24	23	M12×75	80-120	4.1	
6½OD	6.500	500	16583	6.57	7.32		11.10	13.54	0.94	0.91	¾×3	59-89	9.0	
150	168.3	3.5	78	170	189		282	344	24	23	M12×75	80-120	4.1	
6	6.625	500	17227	6.69	7.44		11.10	13.54	0.94	0.91	¾×3	59-89	9.0	
200	219.1	2.8	106	221	243		337	399	28	23	M12×75	80-120	6.2	
8	8.625	400	23359	8.70	9.57		13.27	15.71	1.10	0.91	¾×3	59-89	13.7	
250	273.0	2.8	164	275	297		407	472	28	23	M12×75	80-120	8.3	
10	10.750	400	36287	10.83	11.69		16.02	18.58	1.10	0.91	¾×3	59-89	18.3	
300	323.9	2.8	231	326	352		462	527	28	23	M12×75	80-120	9.8	
12	12.750	400	51045	12.83	13.86		18.19	20.75	1.10	0.91	¾×3	59-89	21.6	

- The max. pipe end separation dimension shown is for system layout purposes only. Style 007D2 is rigid coupling and will not accommodate expansion/contraction or angular movement of the pipe system.
- Working Pressure and end load are total, from internal and external loads based on standard weight steel pipe.
- Max. end gap is for cut grooved standard weight pipe. Values for roll grooved pipe will be half of cut grooved.

