

# Style 705 | Riser Clamp



**Size Range:** 3/4" through 12"

**Material:** Carbon steel

**Finish:** Electro-Galvanized

**Service:** For support of stationary steel pipe risers or conduit.

**Maximum Temperature:** 650° F

**Approvals:** Complies with Federal Specification A-A-1192A (Type 8) WW-H-171-E (Type 8), ANSI/MSS SP-69 and MSS SP-58 (Type 8).

**Installation:** Clamp is fitted and bolted below a coupling, hub or welded lugs on steel pipe (2 lugs up to 3" pipe, 4 lugs up to 12" pipe). Bolt torques should be per industry standards (see page 276).

Clamp is designed for standard steel pipe O.D. and this must be considered in sizing the riser for other types of piping.

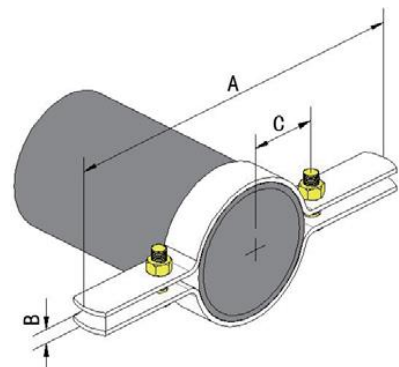

Pipe Size	A	B	C	Max Load	Approx. Wt. Ea.
In/mm	In/mm	In/mm	In/mm	Lbf/N	Lbs./kg
3/4	8.86	0.39	1.28	220	0.99
20	225.0	10.0	32.5	978	0.45
1	8.86	0.39	1.38	220	0.99
25	225.0	10.0	35.0	978	0.45
1 1/4	10.04	0.39	1.57	250	1.28
32	255.0	10.0	40.0	1112	0.58
1 1/2	10.24	0.39	1.77	250	1.30
40	260.0	10.0	45.0	1112	0.59
2	10.24	0.47	2.07	300	1.57
50	260.0	12.0	52.5	1334	0.71
2 1/2	11.22	0.47	2.36	400	1.72
65	285.0	12.0	60.0	1778	0.78
3	11.42	0.47	2.76	500	1.76
80	290.0	12.0	70.0	2223	0.80
3 1/2	12.80	0.47	3.05	500	1.98
90	325.0	12.0	77.5	2223	0.90
4	12.80	0.47	3.25	750	2.01
100	325.0	12.0	82.5	3337	0.91
5	13.78	0.47	3.94	1500	3.02
125	350.0	12.0	100.0	6674	1.37
6	14.76	0.47	4.43	1600	3.31
150	375.0	12.0	112.5	7118	1.50
8	18.50	0.63	5.61	2500	6.39
200	470.0	16.0	142.5	11125	2.90
10	20.24	0.63	6.69	2500	10.21
250	514.0	16.0	170.0	11125	4.63
12	22.76	0.79	7.87	2700	15.32
300	578.0	20.0	200.0	12015	6.95



Shanghai Vision Mechanical Joint Ltd., Co.,

Address: Jinlan Rd. 221, Jiading Industrial Park, Shanghai, China

Tel: 0086-21-5954-6862, 5954-6811, Fax: 0086-21--5954-3888 Web: [www.visionmfr.com](http://www.visionmfr.com)

D-1042E